

ILLINOIS QUALITY AFTERSCHOOL



ENGAGE • CONNECT • SUCCEED

Illinois  
21<sup>st</sup> CCLC  
Spring Conference

May 1, 2014

CONFERENCE AGENDA

# ILLINOIS QUALITY AFTERSCHOOL

[www.sedl.org/afterschool/iqa](http://www.sedl.org/afterschool/iqa)



Join our Facebook group: [www.facebook.com/groups/IQA.SEDL](https://www.facebook.com/groups/IQA.SEDL)

# ENGAGE • CONNECT • SUCCEED

## About the Conference Strands

The Illinois State Board of Education and SEDL would like to welcome you to the to the 2014 Illinois 21<sup>st</sup> Century Community Learning Centers (CCLC) Spring Conference. This conference is designed to provide 21<sup>st</sup> CCLC grantees with strategies, best practices, and program management guidance to assist them in the implementation of the their programs. The conference also provides a forum for grantees, their partners and peers, and other afterschool professionals to network and share information.

We hope that you leave with new ideas, an expanded collegial network, and renewed energy that will support and strengthen your work. To that end, the 2014 conference is organized around three major topics integral to our work developing high-quality afterschool programs. We encourage you to follow the strands that are most relevant to your work.

### Academics Afterschool

Through tutoring, homework help, academic enrichment, and other activities, 21<sup>st</sup> CCLCs provide opportunities for students to improve skills in core academic areas in order to meet local and state academic standards. To encourage and facilitate student learning during the afterschool hours, 21<sup>st</sup> CCLCs use a variety of instructional approaches that engage and challenge students. Presentations for this strand will share examples of successful afterschool practices that focus on expanding learning to support student achievement.

### Afterschool Enrichment

Afterschool enrichment focuses on extending students' knowledge in new ways. These include incorporating technology and the arts into activities to engage students or offering youth development activities that promote social and emotional development. Presentations for this strand will focus on sharing successful strategies and activities that engage and motivate students to regularly attend the afterschool program, fully participate in program activities, and exhibit positive behavioral changes.

### Continuous Program Improvement

High-quality afterschool programs are goal oriented, routinely assess their progress, and make necessary adjustments to remain on track for reaching program goals. These 21<sup>st</sup> CCLCs have a philosophy of continuous improvement that facilitates strong ties with stakeholders and a plan for sustainability. Presentations for this strand will focus on strategies, resources, and tools used in achieving program goals; building staff capacity; gauging program effectiveness; fostering effective communication; maintaining compliance with Illinois State Board of Education and 21<sup>st</sup> CCLC program requirements; collaborating with program partners; and building strong relationships with students and their families.

## ILLINOIS QUALITY AFTERSCHOOL

### Agenda

May 1, 2014

Time	Session	Location
7:30–8:30 a.m.	<b>Check-in and Breakfast</b>	Lower Level Lobby and General Session Room B-11
8:00–8:30 a.m.	<b>STUDENT PERFORMANCE</b> <b>The Legacy Rock Band</b> Center for Community Arts Partnerships (CCAP), Columbia College The Legacy rock band from Pulaski International School of Chicago will get our morning started with some rock and roll. Molded under the hammer-like tutelage of Katie Spero and Zach Kritzer, these young musicians have learned to blend the sounds of drums, guitar, bass, piano, and voice to wield the power of pure rock and roll.	General Session Room B-11
8:30–9:00 a.m.	<b>Opening Session</b>  <b>WELCOME AND GREETINGS</b> Amy Jo Clemens, Assistant Superintendent, Innovation and Improvement Illinois State Board of Education, Springfield, IL Lacy Wood, Project Director Illinois Quality Afterschool, SEDL, Austin, TX	General Session Room B-11
9:00–9:10 a.m.	<b>Break</b>	
9:10–10:25 a.m.	<b>Concurrent Sessions I</b>	
9:10–10:25 a.m.	<b>STRAND I – ACADEMICS AFTERSCHOOL</b>	
9:10–10:25 a.m.	<b>Making Moments Matter in Math Using Common Core Rigor, Fluency, and Fun!</b> Renee Hawthorne, Site Coordinator, 21 <sup>st</sup> Century Preparatory Center, Park Forest–Chicago Heights SD 163, Park Forest, IL Shaunita Jones, Site Coordinator, Algonquin Primary Center, Park Forest–Chicago Heights SD 163, Park Forest, IL You don't need to be a math teacher to help students and parents gain a conceptual understanding of math through procedural skills and fluencies. This session offers hands-on math games, activities, and ideas that can be implemented in the classroom or on the move.	Meeting Room B-7
9:10–10:25 a.m.	<b>Exploring STEM With You for Youth</b> Monique S. McDowell-Russell, You for Youth Training Specialist, Foundations, Inc., Mt. Laurel, NJ Jessica Chung, You for Youth Training Specialist, Foundations, Inc., Mt. Laurel, NJ STEM is for everyone! Learn how You for Youth (Y4Y) can support your program's potential for science, technology, engineering, and math (STEM) by encouraging students' curiosity and making STEM activities real, active, and local. Find local resources to support your STEM programming and learn strategies to coordinate with school-day partners. Please bring a laptop, tablet, or internet-accessible device to explore Y4Y during the session.	Meeting Room B-6

May 1, 2014

Time	Session	Location
9:10–10:25 a.m.	<b>STRAND II – CONTINUOUS PROGRAM IMPROVEMENT</b>	
9:10–10:25 a.m.	<p><b>Turning Bullying Prevention Research Into Action</b></p> <p>Stephanie Roy, Special Projects Managing Coordinator, Center for Schools and Communities, Camp Hill, PA</p> <p>Shileste Overton-Morris, Senior Program Development and Organization Manager, Center for Schools and Communities, Camp Hill, PA</p> <p>As educators, we have heard a great deal about the importance of bullying prevention and intervention during the school day and out-of-school time (OST) settings. Bullying can have detrimental effects on all those involved and yet, people are often left wondering how to prevent it. How do you empower bystanders who witness bullying? How do you cultivate empathy in bullies? And how do you support parents so that they can help keep their children safe? This workshop will move beyond general guidelines and bullying statistics and provide actual tips, techniques, and lesson plans that OST programs can use to cultivate a safe environment where students can learn, develop strong relationships, and have fun.</p>	Meeting Room B-10
9:10–10:25 a.m.	<p><b>Engaging Families Through Afterschool</b></p> <p>Sarah Ogeto, Principal Consultant, Illinois State Board of Education, Chicago, IL</p> <p>This interactive session will focus on how to meaningfully engage afterschool staff, school leaders, and parent leaders in using a walk-through to assess how current family engagement practices are effective and linked to supporting student achievement. Participants will discover the plethora of innovative strategies, tools, and web-based resources available from the Illinois State Board of Education through the Family Engagement Framework guide and Illinoisparents.org website.</p>	Meeting Room B-9
9:10–10:25 a.m.	<p><b>Profile and Performance Information Collection System (PPICS)</b></p> <p>Michael Hutson, Program Associate, American Institutes for Research, Chicago, IL</p> <p>This session will cover data entry for the Annual Performance Report (APR) in the Profile and Performance Information Collection System. All APR sections, general reporting requirements, and common exceptions will be addressed.</p>	Meeting Room B-1
9:10–10:25 a.m.	<p><b>Achieving Their Goals: Building Student Success Through Individualized Learning Plans</b></p> <p>Heather Fox, Project Coordinator, Pathways Resource Center, University of Illinois at Urbana-Champaign, Champaign, IL</p> <p>Individualized Learning Plans (ILPs) are developed through a student-centered process in which all students are guided through career exploration and development. The resulting plan is designed to help them attain career and college readiness. This presentation will provide an overview of ILPs, including benefits, design, and implementation. A new guide for implementing ILPs will be provided. Attendees will have an opportunity to reflect on how to build on their current service model to provide and enhance the ILP processes.</p>	Meeting Room B-3

## ILLINOIS QUALITY AFTERSCHOOL

May 1, 2014

Time	Session	Location
9:10–10:25 a.m.	<b>STRAND III – AFTERSCHOOL ENRICHMENT</b>	
9:10–10:25 a.m.	<p><b>Girls in Motion: Supporting High School Youth in Their Mentorship to Girls</b></p> <p>Rise’ D. Jones, Executive Director, Hamilton Wings, Elgin, IL</p> <p>This workshop will provide participants with strategies for integrating 21<sup>st</sup>-century skills with the leadership development of youth mentors. This workshop is based on a program that involves female high school students as mentors to younger, academically and/or socially challenged students in arts-based enrichment. This session will be of interest to participants who want to support the development of older youth through real-world experiences in which they are peer leaders, program planners, and evaluators.</p>	Meeting Room B-4
9:10–10:25 a.m.	<p><b>Help Students Identify and Meet Career Goals</b></p> <p>Diane Mahinda, Facilitator, Illinois Curriculum Revitalization Project, Springfield, IL</p> <p>Leah Brock, Counseling Services Facilitator, Illinois Curriculum Revitalization Project, Springfield, IL</p> <p>Many students leave high school without setting career goals. When they lack a focus or a purpose to their education, they tend to wander aimlessly towards graduation. This session provides participants with resources and tools to help students set career goals and prepare for college and careers. Resources are from the Illinois Curriculum Revitalization Project, a project funded by the Illinois State Board of Education.</p>	Meeting Room B-8
10:25–10:35 a.m.	<b>Break</b>	
10:35–11:50 a.m.	<b>Concurrent Sessions II</b>	
10:35–11:50 a.m.	<b>STRAND I – ACADEMICS AFTERSCHOOL</b>	
10:35–11:50 a.m.	<p><b>#TeamSTEM: Innovative STEM Activities for Teens on Any Program Budget</b></p> <p>Kelly Williams, Club Director, Union League Boys and Girls Club, Clemente High School Site, Chicago, IL</p> <p>Kristin Allen, Director, Illinois Alliance of Boys and Girls Clubs, Springfield, IL</p> <p>Come learn about effective marketing techniques and innovative activities that keep teens engaged and involved in STEM programming. Find out how to offer activities such as music production, video production, and robotics on any program budget.</p>	Meeting Room B-7

May 1, 2014

Time	Session	Location
10:35–11:50 a.m.	<p><b>Aligning With the School Day With You for Youth</b>                      Monique S. McDowell-Russell, You for Youth Training Specialist, Foundations, Inc., Mt. Laurel, NJ                      Jessica Chung, You for Youth Training Specialist, Foundations, Inc., Mt. Laurel, NJ</p> <p>Explore how to use the You for Youth (Y4Y) web portal to learn about benefits and strategies for aligning learning across in-school and out-of-school experiences. Topics covered will include sharing greater responsibility for student learning, integrating academics into afterschool programming, and partnering effectively with school day staff. Please bring a laptop, tablet, or internet-accessible device to explore Y4Y during the session.</p>	Meeting Room B-6
10:35–11:50 a.m.	<p><b>STRAND II – CONTINUOUS PROGRAM IMPROVEMENT</b></p>	
10:35–11:50 a.m.	<p><b>Family Involvement in Expanded Learning Programs for High School Students</b>                      Paula Egelson, Director of Research, Southern Regional Education Board (SREB), Atlanta, GA</p> <p>Getting families involved in high school educational programs can be a challenge. Learn about family involvement research, elements, strategies, programs, and recommendations that will make your secondary expanded learning program a great success!</p>	Meeting Room B-9
10:35–11:50 a.m.	<p><b>Rtl and 21<sup>st</sup> Century: How to Effectively Meet Student Needs</b>                      Megan Springer, 21<sup>st</sup> Century Site Coordinator, Bloom High School, Chicago Heights, IL                      Tino Villaflor, Science Department Chair, Bloom Township District 206, Chicago Heights, IL                      Dr. Richard Baisa, Science Teacher, 21<sup>st</sup> Century Tutor, Bloom High School, Chicago Heights, IL                      Mariba Woods, 21<sup>st</sup> CCLC Project Director, Bloom District 206, Chicago Heights, IL</p> <p>This presentation will focus on ways to align your 21<sup>st</sup> CCLC program with the Response to Intervention (Rtl) needs of your school and students. Afterschool tutoring is a great resource for students who are struggling and need extra support. Used as a Tier 1, Tier 2, or even Tier 3 intervention, the afterschool tutoring program can transform your Rtl system into a sustainable entity, thus transforming the lives of your students.</p>	Meeting Room B-8

## ILLINOIS QUALITY AFTERSCHOOL

May 1, 2014

Time	Session	Location
10:35–11:50 a.m.	<p><b>Lions and Tigers and Bears, Oh My! Everything You Wanted to Know About the Statewide Evaluation but Were Afraid to Ask</b></p> <p>Leslie Goodyear, Lead Evaluator, Education Development Center, Inc. (EDC), Waltham, MA</p> <p>Katrina Bledsoe, Co-Lead Evaluation and Project Director, Education Development Center, Inc. (EDC), Washington, D.C.</p> <p>Sheila Rodriguez, Research Associate, Education Development Center, Inc. (EDC), Chicago, IL</p> <p>Joshua Cox, Research Assistant, Education Development Center, Inc. (EDC), Chicago, IL</p> <p>This session is designed to provide conference attendees an opportunity to become acquainted with the newly revised spring survey, as well as the initiative logic model, which drives data collection. We will also devote session time to discussing the larger evaluation plan including timing of site visits, participant expectations for those visits, and other data collection efforts.</p>	Meeting Room B-1
10:35–11:50 a.m.	<b>STRAND III – AFTERSCHOOL ENRICHMENT</b>	
10:35–11:50 a.m.	<p><b>Using Project-Based Learning to Engage Youth in College and Career Readiness Exploration</b></p> <p>Nina Lopez, Education Coordinator, Central States SER, Jobs for Progress, Inc., Chicago, IL</p> <p>Adrean Vargas, Site Coordinator, Central States SER, Jobs for Progress, Inc., Chicago, IL</p> <p>This presentation will walk participants through the process of creating project-based learning opportunities for students. Attendees will learn how to incorporate 21<sup>st</sup>-century and employability skills into projects that explore college and careers. This session will equip educators with new project ideas!</p>	Meeting Room B-4
10:35–11:50 a.m.	<p><b>Fostering Youth Entrepreneurism and Engaging Stakeholders Through Mentorship and Experiential Learning</b></p> <p>Ebele Onyema, Director, Youth Organizations Umbrella (Y.O.U.), Evanston, IL</p> <p>Ellen Muench, Experiential Learning Coordinator, Youth Organizations Umbrella (Y.O.U.), Evanston, IL</p> <p>This workshop presents Youth Entrepreneurship Summer (YES!) Camp, an innovative program designed to teach entrepreneurial skills to high school students and engage community stakeholders and potential donors in youth leadership development. YES! Camp meets both enrichment and sustainability goals by allowing youth to embrace their dream careers through hands-on experience. Community members and potential donors serve as mentors and have the opportunity to form a meaningful and lasting connection to and partnership with the program.</p>	Meeting Room B-3
11:50-12:00 p.m.	<b>Break</b>	



May 1, 2014

Time	Session	Location
12:00–1:35 p.m.	<b>Luncheon</b>	General Session Room B-11
	<b>LUNCHEON KEYNOTE</b>	
	<b>Attendance Matters: How Out-of-School Time Can Make a Difference by Reducing Chronic Absence</b>	
	Hedy Chang, Director, Attendance Works, San Francisco, CA	
	Based on research and common sense, we know that when students are chronically absent—missing 10% or more of school for any reason—they are at risk of lower academic achievement and eventually dropping out. The good news is that high-quality afterschool programs have the potential to improve school-day attendance by increasing student engagement, building a strong culture of attendance, and helping schools reach out to students who are struggling with chronic absence. During this session, keynote speaker Hedy Chang will explore how out-of-school time providers can make the most of the opportunity to help children succeed by ensuring that they are in school every day so they can learn.	
1:35–1:45 p.m.	<b>Break</b>	
1:45–3:00 p.m.	<b>Concurrent Sessions III</b>	
1:45–3:00 p.m.	<b>STRAND I – ACADEMICS AFTERSCHOOL</b>	
1:45–3:00 p.m.	<b>Exploring STEM With You for Youth (repeated session)</b>	Meeting Room B-6
	Monique S. McDowell-Russell, You for Youth Training Specialist, Foundations, Inc., Mt. Laurel, NJ	
	Jessica Chung, You for Youth Training Specialist, Foundations, Inc., Mt. Laurel, NJ	
	STEM is for everyone! Learn how You for Youth (Y4Y) can support your program’s potential for science, technology, engineering, and math (STEM) by encouraging students’ curiosity and making STEM activities real, active, and local. Find local resources to support your STEM programming and learn strategies to coordinate with school-day partners. Please bring a laptop, tablet, or internet-accessible device to explore Y4Y during the session.	
1:45–3:00 p.m.	<b>STRAND II – CONTINUOUS PROGRAM IMPROVEMENT</b>	
1:45–3:00 p.m.	<b>Taking a Deeper Dive: Assessing How Your Out-of-School Time Program Can Reduce Chronic Absence</b>	Meeting Room B-10
	Hedy Chang, Director, Attendance Works, San Francisco, CA	
	Designed as an interactive workshop, this session will provide you with opportunities to apply concepts discussed in the keynote session and assess how your program can partner with schools to reduce student absenteeism and educate families about the importance of attendance.	

## ILLINOIS QUALITY AFTERSCHOOL

May 1, 2014

Time	Session	Location
1:45–3:00 p.m.	<p><b>Lions and Tigers and Bears, Oh My! Everything You Wanted to Know About the Statewide Evaluation but Were Afraid to Ask (repeated session )</b></p> <p>Leslie Goodyear, Lead Evaluator, Education Development Center, Inc. (EDC), Waltham, MA</p> <p>Katrina Bledsoe, Co-Lead Evaluation and Project Director, Education Development Center, Inc. (EDC), Washington, D.C.</p> <p>Sheila Rodriguez, Research Associate, Education Development Center, Inc. (EDC), Chicago, IL</p> <p>Joshua Cox, Research Assistant, Education Development Center, Inc. (EDC), Chicago, IL</p> <p>This session is designed to provide conference attendees an opportunity to become acquainted with the newly revised spring survey, as well as the initiative logic model, which drives data collection. We will also devote session time to discussing the larger evaluation plan including timing of site visits, participant expectations for those visits, and other data collection efforts.</p>	Meeting Room B-1
1:45–3:00 p.m.	<p><b>Survival Tips for Resource Coordinators</b></p> <p>Heidi Dye, Program Coordinator, Children’s Home + Aid, Chicago, IL</p> <p>For those who may be new or struggling to survive in the role of resource coordinator, this workshop is for you! The presenter will provide helpful hints and tips she has learned along the way. The focus will be on helping your program go from good to great.</p>	Meeting Room B-9
1:45–3:00 p.m.	<p><b>STRAND III – AFTERSCHOOL ENRICHMENT</b></p>	
1:45–3:00 p.m.	<p><b>Why We Tell the Story: How Improvisation Can Ignite Your Afterschool Program</b></p> <p>Bryan Blanks, Site Coordinator, Stark County High School, Bureau Henry Stark ROE, Toulon, IL</p> <p>Students, Rebels Actin’ Up, Improvisation Group of Stark County High School, Toulon, IL</p> <p>Building a strong high school 21<sup>st</sup> CCLC program that’s vibrant and energetic can be difficult. This session will highlight theatrical strategies to build a program that will not only have the students buzzing but also grab the attention of the community as well. First, students must be comfortable sharing their stories and experiences. Within these stories, a successful program can be built. Members of Rebels Actin’ Up, an improvisation group, will exemplify why we tell the story.</p>	Meeting Room B-7

May 1, 2014

Time	Session	Location
1:45–3:00 p.m.	<p><b>Transforming Lives: A Community-Based Approach to Social Emotional Learning</b></p> <p>Tonantzin Gamboa, Community Schools Manager, Enlace Chicago, Chicago, IL                      Cindy Martinez, Whitney Resource Coordinator, Enlace Chicago, Chicago, IL                      Elias Corral, LVLHS Post Secondary Coordinator, Enlace Chicago, Chicago, IL                      Suzanne Zoheri-Chopra, LVLHS Community Schools Counselor, Enlace Chicago, Chicago, IL                      Alisha Warren, Whitney School Based Mentor, Enlace Chicago, Chicago, IL</p> <p>During this interactive presentation, participants will learn about a community-based approach to engaging youth in programs that impact their social, emotional, and academic success. Enlace Chicago, in partnership with eight Chicago public schools in the Little Village community, transforms school spaces into hubs for community learning that have led to impressive gains in the social emotional learning of Latino students participating in the program.</p>	Meeting Room B-4
3:00–3:10 p.m.	<b>Break</b> ( <i>Refreshments provided</i> )	
3:10–3:30 p.m.	<p><b>STUDENT PERFORMANCE</b></p> <p><b>Rebels Actin' Up Improvisation Group</b></p> <p>Stark County 21<sup>st</sup> CCLC Program</p> <p>The afterschool program, Rebels Actin' Up, allows students to develop a basic understanding of improvisation techniques. Each week students engage in activities that utilize improvisation techniques for a variety of purposes. Students learn how improvisation skills can be utilized within a theatrical setting and for real world application. Students also develop storytelling skills for creative writing and dramatic purposes. During this student performance, conference attendees will see the improv group in action.</p>	General Session Room B-11
3:30–4:30 p.m.	<b>Illinois State Board of Education Sessions</b>	
3:30–4:30 p.m.	<p><b>Project Directors Meeting</b></p> <p>Dora Welker, Division Administrator, Illinois State Board of Education, Springfield, IL                      Sarah McCusker, Principal Consultant, Illinois State Board of Education, Springfield, IL                      Kristy Jones, Principal Consultant, Illinois State Board of Education, Springfield, IL                      Sarah Ogeto, Principal Consultant, Illinois State Board of Education, Chicago, IL                      Tiffany Taylor, Principal Consultant, Illinois State Board of Education, Springfield, IL                      Marla Wiemer, Consultant, Illinois State Board of Education, Springfield, IL</p> <p>During this session project directors will receive updates and information about the Illinois 21<sup>st</sup> CCLC program.</p>	Meeting Room B-10

## ILLINOIS QUALITY AFTERSCHOOL

May 1, 2014

Time	Session	Location
3:30–4:30 p.m.	<b>Next Generation Science Standards in Illinois</b> Gil Downey, Principal Consultant, Illinois State Board of Education, Springfield, IL Tara Bell, Principal Consultant, Illinois State Board of Education, Springfield, IL Participants will have an opportunity to hear an update on Next Generation Science Standards (NGSS) in Illinois. This presentation will include background on the development of NGSS and implications for teaching and learning as we implement the new standards.	General Session Room B-11
4:30 p.m.	<b>Adjourn</b>	

### Prairie Capital Convention Center Floor Plan

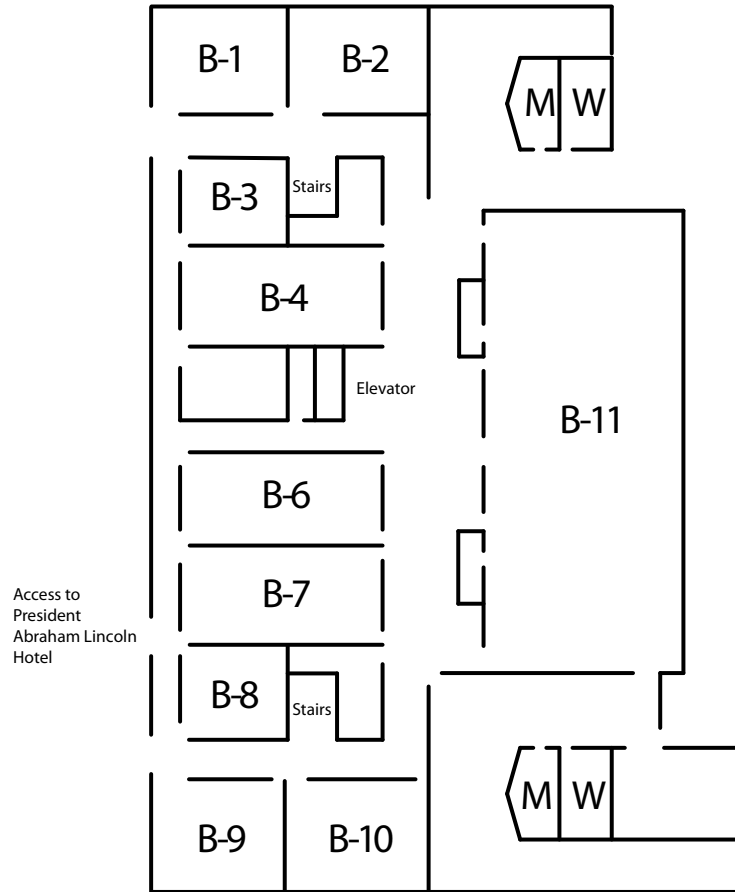



KEYNOTE SPEAKER

Hedy Nai-Lin Chang

**Attendance Works**

*Director*

Hedy Nai-Lin Chang directs Attendance Works, a national- and state-level initiative aimed at advancing student success by addressing chronic absence. A skilled presenter, facilitator, researcher and writer, she co-authored the seminal report, Present, Engaged and Accounted For: The Critical Importance of Addressing Chronic Absence in the Early Grades, as well as numerous other articles about student attendance. Deeply committed to promoting two-generation solutions to achieving a more just and equitable society,

Chang has spent more than two decades working in the fields of family support, family economic success, education and child development. She served as a senior program officer at the Evelyn and Walter Haas Jr. Fund and as co-director of California Tomorrow, a nonprofit committed to drawing strength from cultural, linguistic and racial diversity. In February 2013, Chang was named by the White House as a Champion of Change for her commitment to furthering African American education. Chang is also the mother of two school-aged sons who attend public school in San Francisco.

# ILLINOIS QUALITY AFTERSCHOOL

[www.sedl.org/afterschool/iqa](http://www.sedl.org/afterschool/iqa)



Join our Facebook group: [www.facebook.com/groups/IQA.SEDL](https://www.facebook.com/groups/IQA.SEDL)



**SEDL**



Hosted by the Illinois State Board of Education and SEDL